

# **HMS *Electronics***

5935 Labath Avenue, Rohnert Park, California 94928 Tel: (707)584-8760 Fax: (707)584-7052

## **HS2-MPX Anode Rotator 'HIGH SPEED STARTER'**

**"R VERSION"  
or  
"R/Q VERSION"**

**\*\*\*New\*\*\*  
500 Volt Output Capability  
See Page 3 of manual**

**INSTALLATION AND SERVICE MANUAL**

## CONTENTS

A.	INSTALLATION PLANNING DATA .....	2
B.	INSTALLATION CONNECTIONS	
1.	POWER .....	3
2.	VERIFY LIGHTS .....	4
3.	STATOR CONNECTIONS .....	4-5
4.	INPUTS AND OUTPUTS .....	5-6
5.	DIP SWITCH PROGRAMMING .....	6-8
6.	FLURO & SPOT FILM FUNCTIONS .....	9
C.	OUTLINE OF OPERATION .....	10-12
D.	TROUBLE SHOOTING (& Diagnostics) .....	11-15
E.	TYPICAL SETUP CHART .....	17
E.	PARTS LISTS .....	18-27
F.	SCHEMATIC DRAWINGS .....	28-

## A. INSTALLATION PLANNING DATA

The system consists of a standard 19 inch rack of electronics (approx. 35 pounds) mounted in a NEMA enclosure (also 35 pounds).

---

---

### Power Requirements:

208 to 240 VAC  
50-60 Hz Single Phase  
15 Amp "R" Version  
30 Amp "R/Q" version

277 VAC \*\*\*[Not U.L. Approved]\*\*  
50-60 Hz Single Phase

12 Amp "R" Version  
20 Amp "R/Q" Version

---

---

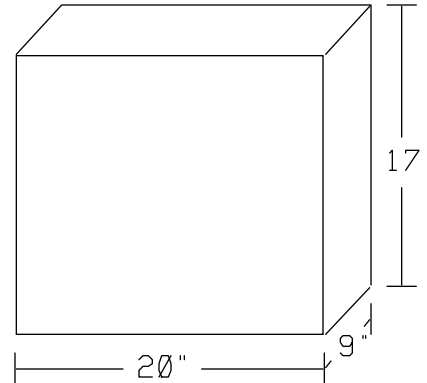

Enclosure Dimensions

Suitable for use on a circuit capable of delivering not more than 5,000 rms Symmetrical Amperes, 240 volts maximum.

### Mounting:

NEMA Type I enclosure  
Total weight 70 pounds.

NOTE: The "R/Q" unit requires branch circuit protection with maximum 30 Amp protector. The "R" unit requires branch circuit protection with a maximum 20 Amp protector. It is recommended that a multi-conductor cable be used for interface connections. The interface wiring or cable must have a 600 Volt insulation. Recommended wire size for interface 20 Gauge maximum.

---

---

The proper sequence of installation steps are as follows.

1. Measure line voltages and connect autotransformer taps.
2. Turn on power and verify lights OK.
3. Connect stators.
4. Connect inputs and outputs.
5. Program DIP switches.
6. Fluoro & Spot-Film Functions.

The proper manner to perform these steps is explained in the following pages.

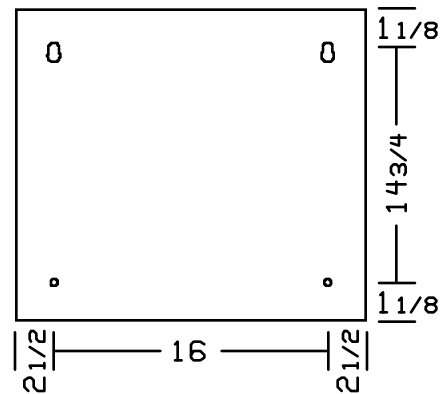

Enclosure mounting hole pattern

## **B. INSTALLATION CONNECTIONS**

### **1. Power.**

#### **Refer to the main schematic**

MAINS: Use maximum 10 Gauge wire or minimum 12 gauge wire for the "R/Q" models. Use maximum 10 Gauge wire or minimum 14 gauge wire for the "R" model.

Utilize the terminals provided in the connector kit for connections of the mains to the circuit breaker. In the event that solid wire is used, as the connectors are intended for stranded wire, the connectors must be soldered to the wire before connection to the circuit breaker.

The incoming AC line goes directly to the circuit breaker below the chassis. Connect the ground wire to the ground lug provided, in the bottom of the cabinet. Measure the incoming voltage leg to leg. Select the proper line matching taps on top of 1T1 (Autotransformer) & 1T2 (low voltage transformer).

The taps are accessible by tipping the 19 inch rack assembly down. Please note that the ground screw for the green grounding wire is used as a stop for the chassis. Once the taps are connected, turn on power and measure for one of the following:

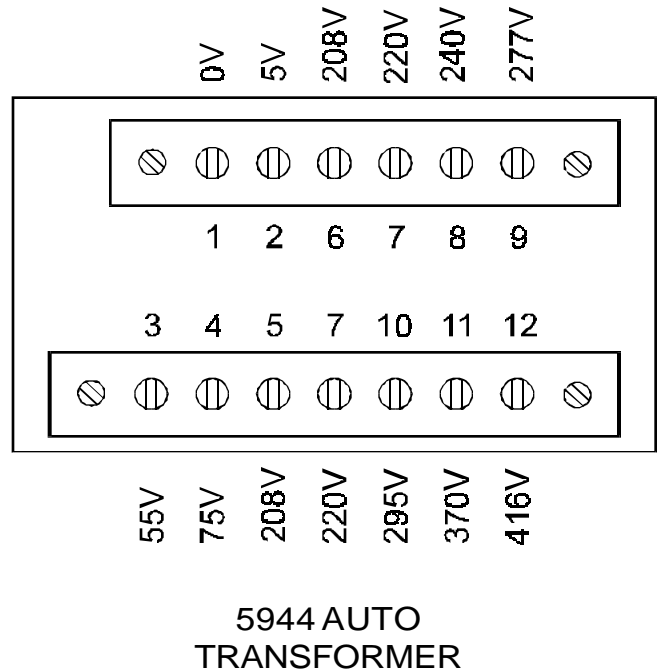

#### **1.1 440 Volts High Speed start voltage**

Measure the 370 volts from tap 1 to the 370 Volt tap (see HS2-MPX Schematic). If this voltage is greater than 385 VAC change the input taps to provide a lower output. Under no condition may the starter be operated with the autotransformer output voltage greater than 385 VAC from tap 1 to the 370 Volt tap. The 5 Volt tap is intended for fine adjustment of the line input.

#### **1.2 500 Volts High Speed start voltage**

Measure the 416 volts from tap 1 to 12 on the autotransformer (see HS2-MPX Schematic). If this voltage is greater than 420 VAC change the input taps to provide a lower output. Under no condition may the starter be operated with the autotransformer output voltage greater than 420 VAC from tap 1 to the 416 Volt tap. The 5 Volt tap is intended for fine adjustment of the line input.

## **2. Verify Lights**

When you apply the power (after the proper taps have been selected), the relays are sequenced. The order of sequence is:

1. Tube 1 [ K1 on CB511]
2. Tube 2 [ K2 on CB511]
3. Tube 3 [ K3 on CB511]
4. Low speed start [ K1 on CB513]
5. Low speed run [ K2 on CB513] & [ K6 on CB511]
6. High speed start [ K5 & K6 and K3 on CB513]
7. High speed run [ K5 & K6 and K4 on CB513] & [ K6 on CB511]

On the light bar, CB515, the "+5" status LED should be on and the "OK" status LED should be flashing at one second intervals.

On the Inverter Driver Board (CB512) all three LED's should be ON and of equal brightness.

On the motherboard (CB517) LED1 & LED2 should be OFF. If any of these lights is not correct, something is wrong. Consult the trouble-shooting section.

If all the lights are OK, proceed with the installation connections.

The **Serv-Norm** (Service-Normal) jumper is provided on the interface board in order to achieve continuous rotation during calibration. In the **SERV** position if a low speed start is given, then the tube is held in low speed until a tube change or high speed is selected. If a high speed signal is given, then the tube is rotated in high speed until a tube change is selected. When the jumper is removed then the tube brakes and returns to normal operation.

**KAUX** relay is under program control and is intended to be interfaced so as to provide separate low speed and high speed interlock to the generator. This is easily accomplished by connecting one leg of the current interlock (Ka-Kp [CB511]) to the common of Kaux and then the low speed interlock connected to the normally closed contact. The high speed interlock would of course be wired to the normally open contact.

With software version 3.x and up, Kaux status is determined by SW1-1 on CB515. If SW1-1 is on, Kaux is programmed on during a brake cycle to allow for interface with generators requiring a tube change inhibit signal. With SW1-1 OFF, Kaux is programmed on with high speed rotation command (requires a High Speed start reason other than FI=High Speed to be on.

## **Installation Connections**

### **3. Stators**

On the edge of the tube selection board (CB 511) are three terminal blocks for the stator connections. Verify the /Q or /R in the model number of the starter to be used with a "Q" or "R" type stator. For R/Q models verify that the program jumpers (dip switches version -6 and up) on interface board (CB515) match the "Q" or "R" type at the appropriate tube selection site. R/Q models are shipped with tubes 1 & 3 selected as "Q" stators and tube 2 selected as an "R" stator. **WARNING!** If a "Q" stator is connected and an "R" type is programmed, damage to the starter may result. Refer to the interface drawing for jumper/switch identification. [ **Tube 1**, jumper/switch right of **D10**: **Tube 2**, jumper/switch right of **D11**: **Tube 3**, jumper/switch right of **D12**].

## B. INSTALLATION CONNECTIONS CONTINUED

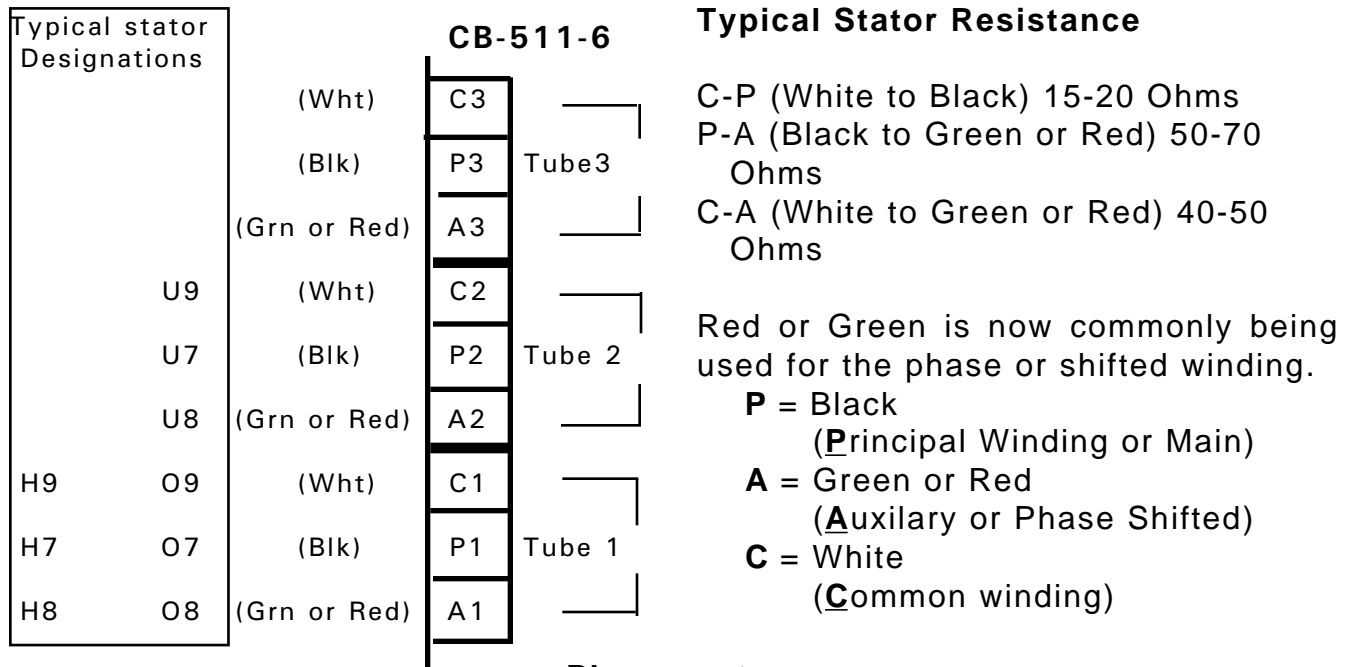

**Please note:**

Any Green wire with a yellow stripe is not a stator wire but a ground wire!

**Incorrect connections of the stator will be detected in high speed and will cause a high speed fault condition!**

### 4. Inputs and Outputs

All generator logic inputs and outputs are made to the J2 connector on the front edge of the interface board (CB515). Using the connector and pins supplied, make a harness.

The interface outputs of this starter are all relay contacts. They will carry a maximum 3 amps at 30 VDC or 250 VAC.

#### Installation Connections

##### J2- Terminals

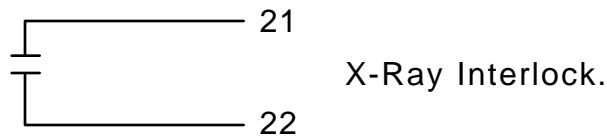

Contacts close when rotor is up to speed and exposures are then permitted.

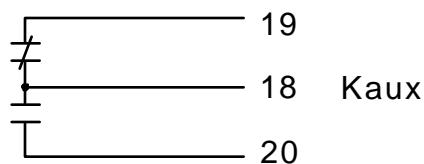

Kaux programmed on with high speed orientation. Software version 3.x and CB515 SW1-1 OFF.

All inputs go into opto-isolators. The standard manner of making a command is to apply 12 to 24 volts AC or DC with the jumpers installed above the 2 watt resistor associated with the input { or 110 volts AC or DC by removing the jumper above the 2 watt resistor associated with the input}. It is preferable to use the power from the generator to supply these command signals. If your generator or spot filmer cannot, then +24 VDC and ground are available on J2 pins. Using this internal DC will expose the ground of the electronics rack to the outside environment and may introduce noise into the system. If you use the internal 24VDC, it may be necessary to use shielded cables between the starter and generator. Tie the shield to chassis ground.

A typical input (somewhat simplified) is as follows:

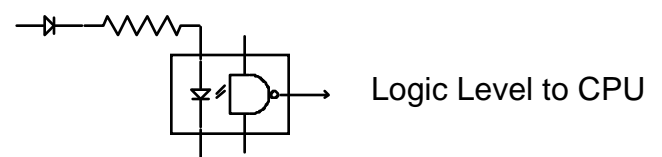

If DC is used, the positive lead must be applied to the proper terminal to turn on the opto-isolator LED. If AC voltage is used, it will be rectified by the diode.

The inputs are:  
J2- terminals

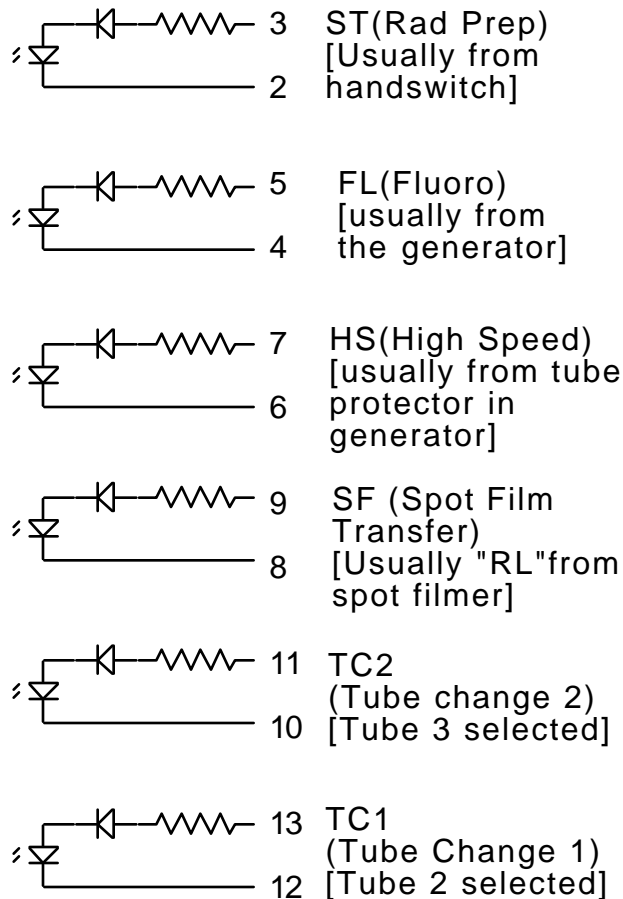

Note: To minimize the wires required from starter to generator, you may link all of the return lines together, assuming all the signals use the same voltage source.

For example:

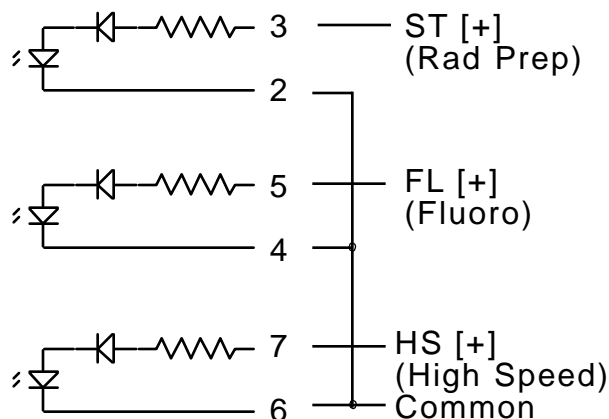

## 5. DIP Switch Programming CB514 (processor)

There are two dip switch banks on the microprocessor boards (CB514). They are called SW1 and SW2.

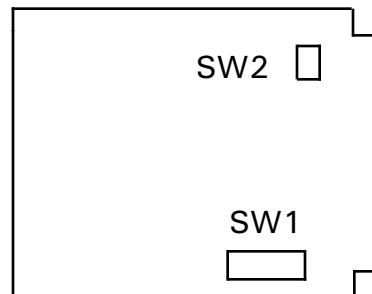

SW1. This group of eight switches controls the accelerate/brake times for Tube 1 and Tube 2.

SW2. This group of four switches controls the accelerate/brake time for Tube 3.

Refer to page 6 for the SW1 and SW2 time table chart.

---

## Dip Switch Programming CB515 (Interface)

There is one switch (SW1) on CB515 interface which is set to enable various options of programming. There is a switch (SW2) for the R/Q model to select the "R" or "Q" stator type, a switch (SW3) to program which fluoro tubes will be held for minutes instead of seconds in high speed. Extended hold for high speed is made by switch selection. For the Fluoro functions to be enabled, the tube rotation must be started with "FL" (Fluoro) or "SF" (Spot-Film).

**B. INSTALLATION CONNECTIONS CONTINUED**

SW1-1 [On]  
K-aux on during brake.

SW1-1 [OFF]  
K-aux on with high speed command.

SW1-2 [On]  
No DC Brake.

SW1-3 [On]  
Hold cancel (generator has hold for low speed fluoro hold time).

SW1-4 [On]  
HS=High Speed Start (HS by itself will initiate High Speed Rotation)

SW1-5&6 [On]  
Control high speed hold time (see High Speed Hold Table)

SW1-7\* [On]  
Forces a .75 second delay while in HIGH SPEED HOLD & before X-Ray when a new start is commanded (removes inter lock for .75S). When tube 3 is not used, insert the Diagnostic Jumper 'D2' on CB514 and the Delay Table will become active thereby making the delay adjustable.

SW1-8 [On]  
Forces high speed FLUORO (FL input will initiate High Speed Rotation and Hold will be enabled, Kaux relay will remain OFF until a normal High Speed command).

	CB514-SW2				Delay
	1	2	3	4	
1	Off	Off	Off	Off	0.60 Sec
2	On	Off	Off	Off	0.65 Sec
3	Off	On	Off	Off	0.70 Sec
4	On	On	Off	Off	0.80 Sec
5	Off	Off	On	Off	0.85 Sec
6	On	Off	On	Off	0.90 Sec
7	Off	On	On	Off	0.95 Sec
8	On	On	On	Off	1.00 Sec
9	Off	Off	Off	On	1.05 Sec
10	On	Off	Off	On	1.10 Sec
11	Off	On	Off	On	1.20 Sec
12	On	On	Off	On	1.30 Sec
13	Off	Off	On	On	1.40 Sec
14	On	Off	On	On	1.50 Sec
15	Off	On	On	On	1.60 Sec
16	On	On	On	On	1.70 Sec

Delay Table  
Selected by Diagnostic Jumper 'D2' on CB514 and SW1-7 on CB515

	SW1-5	SW1-6	Hold	Hold *D3	*Extend	Extend *D3
	CB515	CB515	CB515	CB514	CB515	CB514
1	Off	Off	0 Sec	10 Sec	2 Min	4 Min
2	On	Off	20 Sec	40 Sec	3 Min	6 Min
3	Off	On	35 Sec	70 Sec	5 Min	10 Min
4	On	ON	50 Sec	100 Sec	8 Min	16 Min

**High Speed hold table**

Notes:

\*Extended High Speed Hold: CB515 extended hold switch (SW3) enables extended hold times dependent on tube selection. This is a Fluoro function.

\*D3 Install the Diagnostic Jumper D3 on CB514 to obtain the 'D3' hold times listed in the high speed hold table.



## **DIP Switch Programming Microprocessor**

Select the combination which is appropriate for your tube. SW1-1 through SW1-4 are for tube 1, and SW1-5 through SW1-8 are for tube 2 & SW2-1 through SW2-4 are for tube 3.

To avoid overheating the housing, it is advisable to choose the shortest time combination which fully accelerates the anode.

combination	lo acc. time	hi acc. time	lo-hi acc. time	TUBE1 SW1-				TUBE2 SW1-				TUBE3 SW2-						
				1	2	3	4	5	6	7	8	1	2	3	4			
1	0.8	.80	.7	off	off	off	off	off	off	off	off	off	off	off	off	off	off	
2	0.9	.9	.75	on	off	off	off	on	off	off	off	on	off	off	off	on	off	off
3	1.0	1.0	.8	off	on	off	off	off	on	off	off	off	on	off	off	off	on	off
4	1.2	1.2	.85	on	on	off	off	on	on	off	off	on	on	off	off	on	on	off
5	1.3	1.3	.9	off	off	on	off	off	off	on	off	off	off	on	off	off	on	off
6	1.5	1.5	1.0	on	off	on	off	on	off	on	off	on	off	on	off	on	off	on
7	1.6	1.7	1.2	off	on	on	off	off	on	on	off	off	on	on	off	off	on	on
8	1.8	1.8	1.35	on	on	on	off	on	on	on	off	on	on	on	off	on	on	on
9	2.0	2.0	1.5	off	off	off	on	off	off	off	on	off	off	off	on	off	off	off
10	2.5	2.5	1.8	on	off	off	on	on	off	off	on	on	off	off	on	on	off	off
11	3.0	3.0	2.2	off	on	off	on	off	on	off	on	off	on	off	on	off	on	off
12	3.2	3.2	2.4	on	on	off	on	on	on	off	on	on	on	off	on	on	on	off
13	3.5	3.5	2.6	off	off	on	on	off	off	on	on	off	off	on	on	off	off	on
14	4.0	4.2	3.1	on	off	on	on	on	off	on	on	on	off	on	on	on	off	on
15	4.5	4.8	3.2	off	on	on	on	off	on	on	on	off	on	on	on	off	on	on
16	5.0	5.2	3.5	on	on	on	on	on	on	on	on	on	on	on	on	on	on	on

### Start-Run Delay Times

## B. INSTALLATION CONNECTIONS CONTINUED

### 6. Fluoro and Spot Film functions

Energizing the Fluoro or Spot Film inputs enables a 2 minute hold cycle. That is, the starter maintains LOW SPEED continuous rotation for two minutes following any Fluoro (SF) low speed start condition. If this feature is not desired, set switch SW1-3 on the interface board to on. Another function of the Fluoro-Spot Film inputs is that they also enable the high speed hold function. If rotation is begun by either of these inputs then an optional high speed hold time is enabled. If the high speed hold time is set to zero (see Dip Switch Programming) then the high speed hold is cancelled. See the table on Page 6 for the hold time options.

When in low speed hold, 3300 RPM, only 70% of the start time is required to obtain high speed. This reduces the time delay between Fluoro and spot film exposures.

The "Delay" function set by interface board SW1-7 enables a delay before exposure of .75 seconds when a start command is given while in a hold cycle. This is available in the event that the generator or spot film device has no built-in delay. This delay should allow for necessary filament heat-up. This function causes high speed run to be released and then re-applied .75 seconds later. This action removes the current through the current sensing relays and exposure permission is lost, during the .75 second delay on exposure.

All hold functions are cancelled by a tube change selection.

---

#### **Calibration:**

There are no calibration adjustments.

### C. OUTLINE OF OPERATION

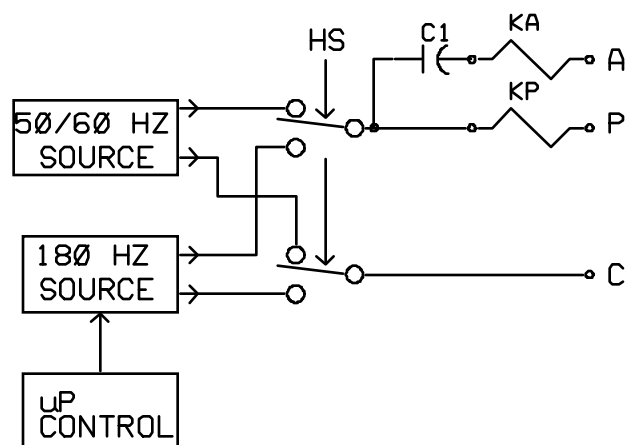

Power Block Diagram

---

The operation of the HS2-MPX is straight forward. There are two AC power supplies 50/60Hz and 180Hz. If low speed stator operation is commanded, the 50/60Hz source will supply 220 VAC for start and 60 VAC for run. For high speed operation, the 180Hz inverter chops 440 VDC (start) and 100 VDC (run) into 180Hz AC, for "R" stator. For "Q" stator 350VDC (start) and 80VDC (run).

The start and run voltages are directed into the phase shift capacitor and current sensing relays. By output relay selection, either of three tubes may be selected.

During high speed braking, 50/60Hz AC is applied to the tube, then DC is applied if DC brake is enabled.

The control of all functions is achieved by relays driven by a microprocessor. The microprocessor responds to commands from the generator. With its memory and the input data, all functions are monitored and current operating status is indicated on LED'S.

## **C. Outline of Operation (Continued)**

Refer to the over all schematic

In low speed operation, 220 VAC or 60 VAC is taken directly from transformer 1T1, passed through relay K5 to [I] and [K] terminals. [K] is the principal winding source. [I] is connected to 1C1 and 1C2 which are the phase shift capacitors. Terminal [J] is the auxiliary winding source.

During acceleration time, K6[CB511] (the run relay) is de-energized. The closed contacts disable the current transformers from coupling the current to the sensing circuits. The AC passes from [J] and [K] directly to whichever tube is selected. For run, K6[CB511] will open its contacts. The AC will now pass through the current sensing circuits and the current sensing will turn on the interlock relay. These current sensing circuits are used to signal to the generator that exposures are permitted.

For high speed operation, either 370 VAC or 72 VAC is directed to 1CR1, (300 VAC or 55 VAC) for "Q" stator. The output on terminals [F] and [G] is a DC Voltage which is applied to the inverter.

On the inverter Driver Board (CB512), the two sets of opto-isolators are driven by the microprocessor port D bits 5 and 6. The timing consists of 5.68 millisecond intervals and is set by internal programing (180Hz). These signals are coupled through the opto- isolators to the bases of four driver transistors. The driver transistors have isolated power supplies as required for operating the inverter transistors.

The Driver and Inverter transistors are set up so that when Inverter transistors Q1 and Q2 are on, Q3 and Q4 are off. With Q1 on, the DC [F] is connected up to [M] and Q2 connects the DC [G] to [L]. When the drive changes polarity, Q1 and Q2 turn off and Q3 and Q4 turn on. This will apply the opposite polarity DC to [L] and [M].

[L] and [M] are the square wave 180Hz AC source. This 180Hz AC is applied via K5 relay contacts (now energized) to [K] and through 1C2 to [J].

Input data, from the generator, is isolated

by opto-isolators to protect the microprocessor from external noise. The conditions of the inputs is shown on status LED'S. The data is passed through input ports to the microprocessor and software routine. Output ports control Driver transistors and operating status LED's. The solid state relay 1SS1 is opened each time any power relay is actuated. This removes incoming power momentarily and prevents contact arcing.

---

**CURRENT DETECTION** during a start cycle is provided by the current circuit located on the mother board (T1, Z2, Z3, R5, Q2). On power-up the current window signal is checked for a high level (+5V) [unless the service jumper is installed]. During a start cycle the current window is checked for active low, 50/60 or 180 HZ **pulses**, indicating that current is flowing. With this signal **CORRECT**, a run cycle will be enabled. If the signal is not correct then the start cycle will be suspended and the program will wait for all start reasons to be released. After start commands are removed, then the tube selection relays will be cycled quickly to give a 'software reset' indication. This safety feature will detect faulty start conditions caused by defective relays, blown fuses, bad connections, faulty relay driver or a defect in the microprocessor board.

**DC BRAKE** is achieved by applying High Speed run signals to appropriate relays ,and the microprocessor turns on 1/2 of the inverter during the brake period. This applies about 60VDC to the stator "Principal" or "Main" winding.

## Review---Current Window

The current in the common of the stator is actively monitored during both low and high speed starts. In low speed, the signal is looked at for a low each time the line crosses through zero. Since the sum of the main and shifted currents should not be a low value, the "Current Window" signal should be low at line crossing through zero. In high speed, the "Current Window" signal is checked for a low each time that the inverter is switched. Again, the sum of the main and shifted currents should not be a low value when the inverter is being switched. In high speed the impedance matching of the main and shifted winding is more critical than in low speed. The windings must be connected properly or the "Current Window" signal will become distorted due to improper phase of the two currents (main and shifted). Therefore, the "Current Window" will not always detect a fault in low speed, but will detect improper connections in high speed. The stator connections when connected backward, will cause the tube to rotate backward in low speed and the tube will come up to proper speed--no problem. However, in high speed the tube will not come up to speed when trying to rotate backward.

## RESET During Operation

**HARDWARE RESET:** This reset is generally caused by arcing of relay contacts during a start, run or brake sequence. This is most likely to occur in the event that the solid state relay is shorted or defective in some way. The unit will act like it was just turned on and all of the relays will be cycled.

**SOFTWARE RESET:** This reset is generally caused by a current phase error in the common of the supply to the stator. If this is the reset condition, then temporarily moving the service-normal jumper on the interface board to the service position will disable this software safety and a normal start-run sequence will complete. The usual cause for this condition is that there is a problem with the connections to the x-ray tube stator windings.

---

**STATOR VOLTAGES** The following voltages +-10% should be the typical output voltages of the starter as measured Common to Principle (C-P).

	<u>START</u>	<u>RUN</u>	<u>BRAKE</u>
Q STATOR	340 VAC 180HZ	60 VAC 180HZ	220 VAC BRAKE1, 50VDC BRAKE2
Q STATOR	220 VAC 60HZ	52 VAC 60HZ	50 VDC BRAKE
R STATOR	440 VAC 180HZ	100 VAC 180HZ	220 VAC BRAKE1, 60VDC BRAKE2
R STATOR	220 VAC 60 HZ	54 VAC 60HZ	60VDC BRAKE

\*\*With tap 12 on the autotransformer selected\*\*

R STATOR ~500 VAC 180HZ 100 VAC 180HZ 220 VAC BRAKE1, 60VDC BRAKE2

## **D. TROUBLE SHOOTING**

Jan 8, 1992

### **Failure of Inverter (CB510):**

Using an Ohmmeter, measure the resistance of the four power transistors. They should all be similar in resistance checks. Generally, the Inverter transistors will short base to collector. If any power transistor block checks shorted, replace it. Also, since the transistor(s) likely would have shorted base-collector, this would have burned out the base resistor and it will need replacing. In the event of a failure of the inverter do a dynamic check of the Driver Board (CB512).

#### **If repeat failures occur:**

1. Check that there is no possibility of the stator wires shorting to each other or to ground as one single arc will instantly destroy the inverter.
2. Check the two current transformers on the Tube Select & Safety board (CB511) to insure that they are not arcing from primary to secondary. They should have infinite resistance from primary to secondary and are insulated to withstand 2000V. After an arc, there is usually some carbon created and some resistance will be able to be measured.
3. An intermittent drive signal from the driver board may cause failures especially for "Q" stators. See 'Driver Board Dynamic Test' to verify proper driver board operation.
4. Check the snubber networks for open 15 Ohm resistors or open .68 microfarad capacitors.

### **Inverter Failure Symptoms**

1. High speed is commended.
2. HS relays and start relay pulls.
3. No high speed inverter signal to tube stator.
4. The starter goes to stand by mode ~ .3 seconds into start.
5. At release of high speed start, AC BRAKE is applied (V3.5 & up software), and then the relays are sequenced as if power had just turned on. This was caused by the current window not being active 180 HZ, i.e. no power to stator or an improper phase angle was detected in the common lead.
6. The storage capacitor will probably be charged to about 460 VDC during the HS start cycle if the cause is failure of the inverter section.

Use Diagnostic 0, Mode 2 to run the driver board and test both driver and inverter boards. (see page 13)

---

---

### **Driver Board Static Test (CB512)**

Feel the 10 watt resistors on the board. All resistors should be cool in standby operation (inverter not running). If any are HOT then the associated driver transistor or its associated opto-isolator are defective and need replacing.

### **Driver Board Dynamic Test (CB512)**

1. Remove the 'Power Relay Board' and the 'Inverter Board'.
3. Put the 'Driver Board' on the Extender Card.
4. Turn the unit on.
5. After a minute or two, all four of the 10 watt resistors should be cold.
6. Use Diagnostic 0, Mode 2 to run the inverter & driver for dynamic testing. (see page 13)
7. On the Driver Board, Successively jumper the 510 ohm 1/4Watt resistor at the output of each of the four driver stages and verify that the appropriate 10 watt resistor begins to heat up. (jumpering the 510 ohm resistor provides a load for the driver stage). You may want to verify about a 4+ VDC drop across the 10 watt resistor with the 510 ohm resistor jumpered.

#### **Test Notes:**

Jumper R2 , R1 gets hot.  
Jumper R7, R6 gets hot.  
Jumper R11, R10 gets hot.  
Jumper R16, R17 gets hot.

## D. TROUBLE SHOOTING CONTINUED

### Power Relay Board (CB513)

Since the relays are all sequenced on and off immediately following the power being turned on, if any relay or relay contacts are suspected just turn power off then after 2 seconds turn power back on and watch for the relay to come on, and its associated contacts to change position. To manually control the relays, use Diagnostic 0, Mode 0 (see page 13 and Table 1 on page 14).

---

### Safety and Tube Select Board (CB511)

In the event of no rotor interlock with normal anode rotation check for the following:

1. Insure that relay K6 comes in with RUN as its contacts have to open to allow for current to pass through the current sensing circuits. Repair sensing circuits as necessary. To manually control the relays on this board use Diagnostic 0, Mode 0 (see page 13 and Table 1 on page 14)
- 

### Microprocessor Board CB514

In the event of a microprocessor board malfunction, the board should be replaced. The following diagram for the light bar is given for your convenience.

	10 +5 Volts
	9 N/C
	8 Autotransformer
	7 Inverter Drive (CB512)
	6 Inverter Drive (CB512)
	5 Run (K6-CB511; K2 or K4-CB513)
	4 High Speed (K5 & K6-CB513)
	3 Tube 3 (K3-CB511)
	2 Tube 2 (K2-CB511)
	1 Tube 1 (K1-CB511)

### CPU Board (CB514) Cont'd

Verify that the "OK" status LED on CB515 flashes at 1 second intervals. If it does not, check for the presence of the 50/60Hz signals from CB515. If the 50/60Hz signals are present and the 1 Hz signal is not flashing then the CPU is likely not running.

The microprocessor board has its own power up reset and watchdog circuit. Verify that power up reset is high. If the reset remains low repair the reset circuit U1. If reset performs properly, check for the two 50/60 Hz pulses to U10 (CA1 pin 40, and CB1 pin 18). The reset chip "DS1232" will maintain a low at the reset output if the 5Volt supply falls below 4.65Volts.

**\*See pages 13-14 for Diagnostic Notes**

---

### Current Safety Mother board

The LED on the mother board should come on during a start cycle (high current) and will be off during standby, (no current flowing). The service position of the jumper on the interface board allows software to disregard the current window signal. This allows for easier trouble shooting.

### Interface Board (CB515)

1. Check the 24 volt unregulated and 5 volt regulated and verify them as being OK.
2. Verify, using the Light Bar as an indicator that the corresponding light illuminates with the appropriate opto-isolator using the J2 connector.
3. Verify the presence of the 50/60Hz signals from U10 in the event that the CPU seems dead as all outputs timing to the relays is derived from the two 50/60Hz signals.  
**Note:** The opto-isolators are open collector output. This means that you can use a jumper to bring the output low. As you bring an opto-isolator output low, the output of the buffer chip U8 should go low and the appropriate LED on the light bar should turn on.
4. Neither buffer chip should be hot. U7 buffer is only read at turn on and after release of a start. If You feel that the two chips are conflicting, remove U7, and try them both in the U8 position, then as you ground each input, each output should go low.

## **Diagnostic Mode Notes for CPU (CB514):**

Version 4.x software and up now does a checksum test on the eprom and a ram test. If the Eprom checksum fails, the Light bar LED 9 will blink. If Ram test fails, the Light bar LED 9 will blink and the solid state relay will be on (LED 8 of the light bar). Starter operation is disabled.

Version 4.1 Adds a test of current window signal during the relay cycle test. If the current window signal is low, fast blink of 'OK' LED on interface board and LED9 of processor board. Starter operation is disabled.

Version 4.1 Adds a delay between turning on relays during power-up to prevent welding of contacts should the solid state relay be shorted.

Version 4.2 keeps software compatible with older processor boards (watchdog circuit).

Note: On older versions of processor boards, (CB514 Rev 4 and older), The starter will appear inoperative with the checksum or Ram check error! (LED9 on the processor board is not driven)

## **HS2 Diagnostics**

These diagnostics allow the service engineer to check out and evaluate the interaction of the processor board and interface board as well as checking all port inputs and outputs of the processor board.

### **Entering Diagnostic Mode:**

1. Turn off Power
2. Remove all boards from the starter except for the processor and interface board (CB514 and CB515). Put the processor board on the extender card.
3. Record settings of SW1 and SW2 on Processor board.
4. Record settings of SW1, SW2 and if you have 'RQ' starter, SW3 on Interface board.
5. Turn off all SW1 on processor board.
6. **Diagnostic 0 (Modes 0-15):**  
Move the diagnostic Jumper from the 'N' to the '0' position on the processor board, turn on power. Diagnostics Modes 0-15 is enabled.

## **Diagnostic 1 (Switch 2 test):**

Move the diagnostic Jumper from the 'N' to the '1' position on the processor board, turn on power, SW2 test is enabled.

**SW2 Test:** As each switch of SW2 is turned on or off, the corresponding LED (1-4) on the light bar should turn on and off. LED 1 of the light bar is nearest SW1 (bottom LED) If any of the four LED's do not follow the switch settings then the processor board is likely defective.

## **Diagnostic Modes SW2 on Processor Board:** (See Table 1 for utilization of these switches.)

SW2-> 1234

Mode 0 [0000]: Each SW1 switch on the processor board is reflected to Port D. Port D bits are indicated by the light bar. If all 8 LED's on the light bar do not reflect the status of SW1 switches, the processor board is likely defective. See Note1

Mode 1 [1000]: Reflect Current Window signal to Port D bit 7 (LED 4) , Short pin 'C' of the processor board to signal ground, or short out Q2 on Mother board to 'simulate' level change on PA7. LED 2 on the mother board should light while the short is present.

Mode 2 [0100]: Run Inverter Timer (Port D bits 5 & 6) & turn on Kaux relay on interface board. Inverter Driver and Inverter boards may be installed for this test.

Mode 3 [1100]: Turn on OK LED on Interface Board. Pin A on processor board should go high.

Mode 4 [0010]: Turn on Kaux relay on Interface Board. Pin 1 on processor board should go high.

Mode 5 [1010]: Turn on Start relay (see LED1 on mother board). Pin D of processor board should be set high. Power Relay Board may be installed for this test.

**Note1:** These diagnostic modes will turn on the relays corresponding to table 1 if the appropriate boards are installed. Damage to Starter could result if not careful!

## **Diagnostic Mode Notes (Cont.)**

Mode 6 [0110]: Reflect IRQA to Port D bit 5 (LED 6), Reflect IRQB to Port D bit 6 (LED 7).

Mode 7 [1110]: Each SW1 switch on the interface board is reflected to Port D. Signal 'OE2' (pin F ) is output low to enable U9 on the interface board. If pin F does not go low, replace the processor board. See Note1

Mode 8 [0001]: Each input from the interface board opto couplers is reflected to Port D. Signal 'OE1' (pin E) of the processor board is output low to enable U8 on the interface board. If pin E does not go low, replace the processor board. Since the opto couplers are open collector devices, each input can be activated by shorting pin 4 of the associated opto coupler to logic 0volts (signal ground). See Note1

\*\*\*\*\*

**Tube select and safety board (CB511) may be installed for Modes 9-11. If Q stator, check the operation of SW2 on the interface board and enabling of the Kr-q relay mounted on the chassis.)**

\*\*\*\*\*

Mode 9 [1001]: Turn on Tube 1, and Reflect Extended Time switch (SW3-1 on Interface Board) to Port D bit 3 (4th LED from bottom). Check SW2-1 on Interface board for Q select if applicable.

Mode 10 [0101]: Turn on Tube 2 and Reflect Extended Time switch (SW3-2 on Interface Board) to Port D bit 3 (4th LED from bottom). Check SW2-2 on Interface board for Q select if applicable.

Mode 11 [1101]: Turn on Tube 3 and Reflect Extended Time switch (SW3-3 on Interface Board) to Port D bit 3 (4th LED from bottom). Check SW2-3 on Interface board for Q select if applicable.

Modes 12-15 are reserved.

.....

Port D bit assignments (bits 0-7), bit 0 is closest to SW1

PD0 = Tube 1

PD1 = Tube 2

PD2 = Tube 3

PD3 = High Speed Relays (K5 & K6 Power Relay Board)

PD4 = Run Relay (K2 for low speed, K4 for high speed, Power Relay Board), and current detection enable (X-ray Inter lock) on the Tube Select & Safety board.

PD5 = 1/2 inverter drive (Inverter Driver Board, CB512-15)

PD6 = 1/2 inverter drive (Inverter Driver Board, CB512-13)

PD7 = autotransformer (solid state relay enable)

Note: The start relay (K1 for low speed, K3 for high speed) is enabled by PA6 and Q1 on the Mother Board and is therefore not driven by Port D.

TABLE 1

Normal Operation: To return to normal starter operation, simply turn the power on with the Diagnostic jumper removed or in the "N" position.



## **D. TROUBLE SHOOTING CONTINUED**

### **General**

The starter can be partially checked out without the microprocessor board installed. This should only be done if necessary to verify that everything else is OK. With the CPU board removed, make appropriate jumpers to ground on each of the relay drive outputs, in order to activate each relay in turn.

When power is first applied each of the relays are turned on in sequence. This is a simple routine which is intended to give an audio or visual that the microprocessor is running and controlling the relays.

## **E. TYPICAL SETUP CHART**

SW1-	1	2	3	4	5	6	7	8
Fischer	1	X	0	0	X	X	X	0*
G.E.	1	X	1	0	X	X	X	X*
Raytheon	1	X	1	0	X	X	X	X*
Shimadzu	0	X	0	1	X	X	X	X*

0=OFF  
X=DON'T CARE

1=ON

\* May be used for Spot-Film Camera input when High Speed is desired.

### **Typical Setup Table CB515 Interface**

### **Test Fixture**

A test fixture is available for ease of test and trouble shooting the HS2 starter. The test fixture is plugged into the J2 connector on the interface and works both 24volt and 110volt AC configurations. The fixture is available for \$65.00.

## E. PARTS LISTS

### CB510-2 INVERTER BOARD

<u>REFERENCE</u>	<u>DESCRIPT</u>	<u>PART NUMBER</u>
510-2-C1	CAPACITOR, METAL FILM	.68MFD @ 400VDC MF/1.5
510-2-C2	CAPACITOR, METAL FILM	.68MFD @ 400VDC MF/1.5
510-2-C3	CAPACITOR, METAL FILM	.68MFD @ 400VDC MF/1.5
510-2-C4	CAPACITOR, METAL FILM	.68MFD @ 400VDC MF/1.5
510-2-EJ1	EJECTOR LEVER	S-202
510-2-EJ2	EJECTOR LEVER	S-202
510-2-PB1:Q2/Q3	POWER TRANSISTOR BLOCK	CC50R1000K
510-2-PB2:Q1/Q4	POWER TRANSISTOR BLOCK	CC50R1000K
510-2-R1	RESISTOR, 5W	15 OHM 5W WW
510-2-R10	RESISTOR, 2W	18 OHM 2W METAL
510-2-R11	RESISTOR, 2W	18 OHM 2W METAL
510-2-R12	RESISTOR, 2W	18 OHM 2W METAL
510-2-R2	RESISTOR, 5W	15 OHM 5W WW
510-2-R3	RESISTOR, 5W	15 OHM 5W WW
510-2-R4	RESISTOR, 5W	15 OHM 5W WW
510-2-R5	RESISTOR, 2W	56K OHM 2W METAL
510-2-R6	RESISTOR, 2W	56K OHM 2W METAL
510-2-R7	RESISTOR, 2W	56K OHM 2W METAL
510-2-R8	RESISTOR, 2W	56K OHM 2W METAL
510-2-R9	RESISTOR, 2W	18 OHM 2W METAL
510-2-W1	2" WIRE, .110 PUSH-ON	2" WIRE, .110 PUSH-ON
510-2-W2	2" WIRE, .110 PUSH-ON	2" WIRE, .110 PUSH-ON
510-2-W3	2" WIRE, .110 PUSH-ON	2" WIRE, .110 PUSH-ON
510-2-W4	2" WIRE, .110 PUSH-ON	2" WIRE, .110 PUSH-ON
CB510-2	CIRCUIT BOARD	CB510-PWB

**E. PARTS LISTS CONTINUED:**

**CB511-6**  
**TUBE SELECT & SAFETY**

<b><u>REFERENCE</u></b>	<b><u>DESCRIPT</u></b>	<b><u>PART N</u></b>
511-7-1 (LED)	LED	3MM RED
511-7-2 (LED)	LED	3MM RED
511-7-C1	CAPACITOR, AE/A	22MFD @ 35VDC AE/A/.1
511-7-C2	CAPACITOR, AE/A	22MFD @ 35VDC AE/A/.1
511-7-CR1	BRIDGE RECTIFIER	1 AMP 200V DIP BRIDGE
511-7-CR2	RECTIFIER	1N4004
511-7-CR3	BRIDGE RECTIFIER	1 AMP 200V DIP BRIDGE
511-7-CR4	RECTIFIER	1N4004
511-7-EJ1	EJECTOR LEVER	S-202
511-7-K1	RELAY, PC 24VDC	G4W-2212P-US-TV5-HP24VDC
511-7-K2	RELAY, PC 24VDC	G4W-2212P-US-TV5-HP24VDC
511-7-K3	RELAY, PC 24VDC	G4W-2212P-US-TV5-HP24VDC
511-7-K4	RELAY, PC 24VDC	JW1AFEN-DC24V
511-7-K6	RELAY, PC DPDT	HB2-DC24V
511-7-Q1	TRANSISTOR, TO92	2N5307
511-7-Q2	TRANSISTOR, TO92	2N5307
511-7-R1	RESISTOR, 1W	150 OHM 1W METAL
511-7-R10	RESISTOR, 1/4W	33K OHM
511-7-R2	RESISTOR, 1W	150 OHM 1W METAL
511-7-R3	RESISTOR, 1/4W	10K OHM
511-7-R4	RESISTOR, 1/4W	1K OHM
511-7-R5	RESISTOR, 1/4W	33K OHM
511-7-R6	RESISTOR, 1W	150 OHM 1W METAL
511-7-R7	RESISTOR, 1W	150 OHM 1W METAL
511-7-R8	RESISTOR, 1/4W	10K OHM
511-7-R9	RESISTOR, 1/4W	1K OHM
511-7-T1	TRANSFORMER, CURREN	4548D
511-7-T2	TRANSFORMER, CURREN	4548D
511-7-TB1	TERMINAL BLOCK	6PCV-03
511-7-TB2	TERMINAL BLOCK	6PCV-03
511-7-TB3	TERMINAL BLOCK	6PCV-03
511-7-Z1	ZENER DIODE, .4W 5.1V	1N759
511-7-Z2	ZENER DIODE, .4W 3.3V	1N746
511-7-Z3	ZENER DIODE, .4W 5.1V	1N759
511-7-Z4	ZENER DIODE, .4W 3.3V	1N746
CB511-7	CIRCUIT BOARD	CB511-PWB

## E. PARTS LISTS CONTINUED:

### **CB512-5 DRIVER BOARD**

<u>REFERENCE</u>	<u>DESCRIPT</u>	<u>PART N</u>
512-5-C1	CAPACITOR, AE/R	3300MFD @ 16VDC AE/R/.3
512-5-C2	CAPACITOR, MYLAR	.01MFD @ 63VDC MF/.2
512-5-C3	CAPACITOR, AE/R	3300MFD @ 16VDC AE/R/.3
512-5-C4	CAPACITOR, MYLAR	.01MFD @ 63VDC MF/.2
512-5-C5	CAPACITOR, AE/R	3300MFD @ 16VDC AE/R/.3
512-5-C6	CAPACITOR, MYLAR	.01MFD @ 63VDC MF/.2
512-5-C7	CAPACITOR, AE/R	3300MFD @ 16VDC AE/R/.3
512-5-C8	CAPACITOR, MYLAR	.01MFD @ 63VDC MF/.2
512-5-D1	RECTIFIER	1N4004
512-5-D10	RECTIFIER	1N4007
512-5-D11	DIODE	1N4148
512-5-D12	DIODE	1N4148
512-5-D2	RECTIFIER	1N4004
512-5-D3	RECTIFIER	1N4007
512-5-D4	RECTIFIER	1N4004
512-5-D5	RECTIFIER	1N4004
512-5-D6	RECTIFIER	1N4007
512-5-D7	RECTIFIER	1N4004
512-5-D8	RECTIFIER	1N4004
512-5-D9	RECTIFIER	1N4007
512-5-EJ1	EJECTOR LEVER	S-202
512-5-EJ2	EJECTOR LEVER	S-202
512-5-LED1	LED	3MM RED
512-5-LED2	LED	3MM RED
512-5-LED3	LED	3MM RED
512-5-Q1	TRANSISTOR, TO220	TIP106
512-5-Q1HS	HEAT SINK, TO220 (AAVID)	5741-02-B00000
512-5-Q2	TRANSISTOR, TO220	TIP106
512-5-Q2HS	HEAT SINK, TO220 (AAVID)	5741-02-B00000
512-5-Q3	TRANSISTOR, TO220	TIP106
512-5-Q3HS	HEAT SINK, TO220 (AAVID)	5741-02-B00000
512-5-Q4	TRANSISTOR, TO220	TIP106
512-5-Q4HS	HEAT SINK, TO220 (AAVID)	5741-02-B00000
512-5-R1	RESISTOR, 10W	5 OHM 10W WW
512-5-R10	RESISTOR, 1/4W	330 OHM
512-5-R11	RESISTOR, 1/4W	510 OHM
512-5-R12	RESISTOR, 10W	5 OHM 10W WW
512-5-R13	RESISTOR, 1/4W	330 OHM
512-5-R14	RESISTOR, 1/4W	510 OHM
512-5-R15	RESISTOR, 1/4W	2K OHM
512-5-R16	RESISTOR, 1/4W	510 OHM
512-5-R17	RESISTOR, 10W	5 OHM 10W WW
512-5-R18	RESISTOR, 1/4W	330 OHM
512-5-R19	RESISTOR, 1/4W	510 OHM
512-5-R2	RESISTOR, 1/4W	510 OHM
512-5-R20	RESISTOR, 1/4W	2K OHM
512-5-R21	RESISTOR, 1/4W	2K OHM
512-5-R3	RESISTOR, 1/4W	2K OHM
512-5-R4	RESISTOR, 1/4W	510 OHM

## **E. PARTS LISTS CONTINUED:**

512-5-R5	RESISTOR, 1/4W	330 OHM
512-5-R6	RESISTOR, 10W	5 OHM 10W WW
512-5-R7	RESISTOR, 1/4W	510 OHM
512-5-R8	RESISTOR, 1/4W	2K OHM
512-5-R9	RESISTOR, 1/4W	510 OHM
512-5-U1	OPTO ISOLATOR, SCHMIDT	H11L1
512-5-U1S	SOCKET, IC 6 PIN	6 PIN DIP /.3
512-5-U2	OPTO ISOLATOR, SCHMIDT	H11L1
512-5-U2S	SOCKET, IC 6 PIN	6 PIN DIP /.3
512-5-U3	OPTO ISOLATOR, SCHMIDT	H11L1
512-5-U3S	SOCKET, IC 6 PIN	6 PIN DIP /.3
512-5-U4	OPTO ISOLATOR, SCHMIDT	H11L1
512-5-U4S	SOCKET, IC 6 PIN	6 PIN DIP /.3
512-5-W1	RESISTOR, ZERO OHM	ZERO OHM RESISTOR
512-5-W2	RESISTOR, ZERO OHM	ZERO OHM RESISTOR
512-5-W3	RESISTOR, ZERO OHM	ZERO OHM RESISTOR
CB512-5	CIRCUIT BOARD	CB512-PWB

**E. PARTS LISTS CONTINUED:**

**CB513-5**  
**POWER RELAY BOARD**

<b><u>REFERENCE</u></b>	<b><u>DESCRIPT</u></b>	<b><u>PART N</u></b>
513-5-D1	RECTIFIER	1N4004
513-5-D2	RECTIFIER	1N4004
513-5-D3	RECTIFIER	1N4004
513-5-D4	RECTIFIER	1N4004
513-5-D5	RECTIFIER	1N4004
513-5-D6	RECTIFIER	1N4004
513-5-D7	RECTIFIER	1N4004
513-5-D8	RECTIFIER	1N4004
513-5-EJ1	EJECTOR LEVER	S-202
513-5-EJ2	EJECTOR LEVER	S-202
513-5-K1	RELAY, PC DPDT	G4W-2212P-US-TV5-HP24VDC
513-5-K2	RELAY, PC DPDT	RM 207 024
513-5-K3	RELAY, PC DPDT	G4W-2212P-US-TV5-HP24VDC
513-5-K4	RELAY, PC DPDT	RM 207 024
513-5-K5	RELAY, PC DPDT	RM 207 024
513-5-K6	RELAY, PC DPDT	RM 207 024
513-5-R1	RESISTOR 10K 10W	10K OHM 10W WW
CB513-5	CIRCUIT BOARD	CB513-PWB

## E. PARTS LISTS CONTINUED:

### **CB514-6A** **MICROPROCESSOR BOARD**

<b><u>Reference</u></b>	<b><u>Description</u></b>	<b><u>Part Number</u></b>
514-5-C1	CAPACITOR, TANTALUM	1.0MFD @ 35VDC T/.1
514-5-C2	CAPACITOR, TANTALUM	1.0MFD @ 35VDC T/.1
514-5-C3	CAPACITOR, TANTALUM	1.0MFD @ 35VDC T/.1
514-5-C4	CAPACITOR, MYLAR	.1MFD @ 63VDC M/.2
514-5-C5	CAPACITOR, MYLAR	.01MFD @ 63VDC M/.2
514-5-DS1	LIGHT BAR	10 SEG LIGHT BAR, RED
514-5-EJ1	EJECTOR LEVER	S-202
514-5-EJ2	EJECTOR LEVER	S-202
514-5-Q1	TRANSISTOR, TO92	PN2222A
514-5-R1	RESISTOR, 1/4W	2K OHM
514-5-R2	RESISTOR, 1/4W	3K OHM
514-5-R3	RESISTOR, 1/4W	390 OHM
514-5-R4	SIP RESISTOR	CTS770-101-391
514-5-SW1	SWITCH, DIP	8 POS. DIP SWITCH
514-5-SW2	SWITCH, DIP	4 POS. DIP SWITCH
514-5-TPG	TEST POINT (WHITE)	151-201
514-5-U1	IC, RESET	DS1232
514-5-U10	IC, I/O TIMER	R6522
514-5-U2	IC, DECODER	74HCT138
514-5-U3	IC, OSCILLATOR	OSC 1.000 MHZ
514-5-U4	IC, MICROPROCESSOR	R65(C)02
514-5-U5	IC, EPROM	27C64 (PROGRAMMED)
514-5-U5-S	SOCKET, IC 28 PIN	28 PIN DIP /.6
514-5-U6	IC, RAM	2K X 8 (24 PIN)
514-5-U7	IC, I/O TIMER	R6522
514-5-U8	IC, OCTAL BUFFER	74HCT541
514-5-U9	IC, OCTAL RELAY DRIVER	ULN2803
514-5-U9-S	SOCKET, IC 18 PIN	18 PIN DIP /.3
CB514-5	CIRCUIT BOARD	CB514-PWB

## E. PARTS LISTS CONTINUED:

### **CB515-6** **INTERFACE BOARD**

<u>REFERENCE</u>	<u>DESCRIPT</u>	<u>PART N</u>
515-6-C1	CAPACITOR, AE/R	33MFD @ 35VDC AE/R/.1
515-6-C10	CAPACITOR, MYLAR	.01MFD @ 63VDC M/.2
515-6-C11	CAPACITOR, TANTALUM	1.0MFD @ 35VDC T/.1
515-6-C2	CAPACITOR, AE/R	33MFD @ 35VDC AE/R/.1
515-6-C3	CAPACITOR, AE/R	33MFD @ 35VDC AE/R/.1
515-6-C4	CAPACITOR, AE/R	33MFD @ 35VDC AE/R/.1
515-6-C5	CAPACITOR, AE/R	33MFD @ 35VDC AE/R/.1
515-6-C6	CAPACITOR, AE/R	33MFD @ 35VDC AE/R/.1
515-6-C7	CAPACITOR, TANTALUM	1.0MFD @ 35VDC T/.1
515-6-C8	CAPACITOR, AE/R	220MFD @ 50VDC AE/A/1.2
515-6-C9	CAPACITOR, AE/A	2200MFD @ 35VDC AE/A/1.6
515-6-CR14	BRIDGE RECTIFIER	2 AMP 200V RECT. BRIDGE
515-6-D1	RECTIFIER	1N4004
515-6-D10	DIODE	1N4148
515-6-D11	DIODE	1N4148
515-6-D12	DIODE	1N4148
515-6-D13	DIODE	1N4148
515-6-D14	DIODE	1N4148
515-6-D15	DIODE	1N4148
515-6-D16	ZENER DIODE, .4W 5.1V	1N751
515-6-D2	RECTIFIER	1N4004
515-6-D3	RECTIFIER	1N4004
515-6-D4	RECTIFIER	1N4004
515-6-D5	RECTIFIER	1N4004
515-6-D6	RECTIFIER	1N4004
515-6-D7	RECTIFIER	1N4004
515-6-D8	ZENER DIODE, .4W 5.1V	1N751
515-6-D9	ZENER DIODE, .4W 5.1V	1N751
515-6-EJ1	EJECTOR LEVER	S-202
515-6-EJ2	EJECTOR LEVER	S-202
515-6-J2A	HEADER, 11 X 156	09-60-1111 (MOLEX)
515-6-J2B	HEADER, 11 X 156	09-60-1111 (MOLEX)
515-6-J3	HEADER, 3 PIN	3 PIN HEADER .1X3 ST.
515-6-K1	RELAY, PC 24VDC	JW1FEN-DC24V
515-6-LB1	LIGHT BAR	10 SEG LIGHT BAR, RED
515-6-P3	SHORTING PLUG	SHORTING PLUG, W/HANDLE
515-6-Q1	TRANSISTOR, TO220	TIP106
515-6-Q2	TRANSISTOR, TO92	PN2222A
515-6-Q3	TRANSISTOR, TO92	PN2222A
515-6-R1	RESISTOR, 2W	5.6K OHM 2W METAL
515-6-R10	RESISTOR, 1/4W	510 OHM
515-6-R11	RESISTOR, 1/4W	1K OHM
515-6-R12	RESISTOR, 1/4W	1K OHM
515-6-R13	RESISTOR, 2W	5.6K OHM 2W METAL
515-6-R14	RESISTOR, 1/4W	510 OHM
515-6-R15	RESISTOR, 1/4W	1K OHM
515-6-R16	RESISTOR, 1/4W	1K OHM
515-6-R17	RESISTOR, 2W	5.6K OHM 2W METAL
515-6-R18	RESISTOR, 1/4W	510 OHM
515-6-R19	RESISTOR, 1/4W	1K OHM
515-6-R2	RESISTOR, 1/4W	510 OHM



## E. PARTS LISTS CONTINUED:

515-6-R20	RESISTOR, 1/4W	1K OHM
515-6-R21	RESISTOR, 2W	5.6K OHM 2W METAL
515-6-R22	RESISTOR, 1/4W	510 OHM
515-6-R23	RESISTOR, 1/4W	1K OHM
515-6-R24	RESISTOR, 1/4W	1K OHM
515-6-R25	RESISTOR, 1/4W	10K OHM
515-6-R26	RESISTOR, 1/4W	10K OHM
515-6-R27	RESISTOR, 1/4W	10K OHM
515-6-R28	RESISTOR, 1/4W	10K OHM
515-6-R29	RESISTOR, 1/4W	10K OHM
515-6-R3	RESISTOR, 1/4W	1K OHM
515-6-R30	RESISTOR, 1/4W	10K OHM
515-6-R31	RESISTOR, 1/4W	10K OHM
515-6-R32	RESISTOR, 1/4W	10K OHM
515-6-R33	RESISTOR, 1/4W	47K OHM
515-6-R34	RESISTOR, 1/4W	47K OHM
515-6-R35	RESISTOR, 1/4W	10K OHM
515-6-R36	RESISTOR, 1/4W	1K OHM
515-6-R37	RESISTOR, 1/4W	200 OHM
515-6-R38	RESISTOR, 1/4W	390 OHM
515-6-R4	RESISTOR, 1/4W	1K OHM
515-6-R5	RESISTOR, 2W	5.6K OHM 2W METAL
515-6-R6	RESISTOR, 1/4W	510 OHM
515-6-R7	RESISTOR, 1/4W	1K OHM
515-6-R8	RESISTOR, 1/4W	1K OHM
515-6-R9	RESISTOR, 2W	5.6K OHM 2W METAL
515-6-RP1	SIP RESISTOR 390OHM	770-101-R390
515-6-SW1	SWITCH, DIP	8 POS. DIP SWITCH
515-6-SW2	SWITCH, DIP	3 POS. DIP SWITCH
515-6-SW3	SWITCH, DIP	3 POS. DIP SWITCH
515-6-U1	IC, OPTO ISOLATOR, SCHMID	H11L1
515-6-U10	IC, COMPARATOR	LM393N
515-6-U10S	SOCKET, IC 8 PIN	8 PIN DIP /.3
515-6-U1S	SOCKET, IC 6 PIN	6 PIN DIP /.3
515-6-U2	IC, OPTO ISOLATOR, SCHMID	H11L1
515-6-U2S	SOCKET, IC 6 PIN	6 PIN DIP /.3
515-6-U3	IC, OPTO ISOLATOR, SCHMID	H11L1
515-6-U3S	SOCKET, IC 6 PIN	6 PIN DIP /.3
515-6-U4	IC, OPTO ISOLATOR, SCHMID	H11L1
515-6-U4S	SOCKET, IC 6 PIN	6 PIN DIP /.3
515-6-U5	IC, OPTO ISOLATOR, SCHMID	H11L1
515-6-U5S	SOCKET, IC 6 PIN	6 PIN DIP /.3
515-6-U6	IC, OPTO ISOLATOR, SCHMID	H11L1
515-6-U6S	SWITCH, DIP	6 POS. DIP SWITCH
515-6-U7	IC, OCTAL BUFFER	74LS541
515-6-U7S	SOCKET, IC 20 PIN	20 PIN DIP /.3
515-6-U8	IC, OCTAL BUFFER	74LS541
515-6-U8S	SOCKET, IC 20 PIN	20 PIN DIP /.3
515-6-U9	IC, RELAY DRIVER	75452N
515-6-U9S	SOCKET, IC 8 PIN	8 PIN DIP /.3
CB515-5	CIRCUIT BOARD	CB515-PWB

**E. PARTS LISTS CONTINUED:****CB517-5A**  
**Mother Board**

<b><u>REFERENCE</u></b>	<b><u>DESCRIPT</u></b>	<b><u>PART N</u></b>
CB517-5	CIRCUIT BOARD	CB517-PWB
CB517-5-CR2	BRIDGE RECTIFIER	1.5 AMP 200V (ROUND)
CB517-5-D1	RECTIFIER	1N4004
CB517-5-J510	CONNECTOR, (CINCH)	50-22SN-5 22X156 SINGLE
CB517-5-J511	CONNECTOR, (CINCH)	50-22SN-5 22X156 SINGLE
CB517-5-J512	CONNECTOR, (CINCH)	50-22SN-5 22X156 SINGLE
CB517-5-J513	CONNECTOR, (CINCH)	50-44SN-1 22X156 DUAL
CB517-5-J514	CONNECTOR, (CINCH)	50-44SN-1 22X156 DUAL
CB517-5-J515	CONNECTOR, (CINCH)	50-44SN-1 22X156 DUAL
CB517-5-LED1	LED	3MM RED
CB517-5-LED2	LED	3MM RED
CB517-5-Q1	TRANSISTOR, TO92	2N5307
CB517-5-Q2	TRANSISTOR, TO92	PN2222A
CB517-5-R1	RESISTOR, 1/4W	10K OHM
CB517-5-R10	RESISTOR, 10W	15 OHM 10W WW
CB517-5-R2	RESISTOR, 1/4W	2K OHM
CB517-5-R3	RESISTOR, 1/4W	200 OHM
CB517-5-R4	RESISTOR, 1/4W	3K OHM
CB517-5-R5	RESISTOR, 1/4W	1K OHM
CB517-5-R6	RESISTOR, 1/4W	390 OHM
CB517-5-R7	RESISTOR, 2W	56K OHM 2W METAL
CB517-5-R8	RESISTOR, 2W	56K OHM 2W METAL
CB517-5-R9	RESISTOR, 2W	56K OHM 2W METAL
CB517-5-T1	TRANSFORMER, CURRENT	4548D
CB517-5-Z1	VOLTAGE REG, 1 AMP 5V	7805A
CB517-5-Z2	ZENER DIODE, 1W 12V	1N4742A
CB517-5-Z3	ZENER DIODE, .4W 3.3V	1N746

**E. PARTS LISTS CONTINUED:****MISC. CHASSIS PARTS**  
**HS2-MPX STARTER**

<b><u>REFERENCE</u></b>	<b><u>DESCRIPT</u></b>	<b><u>PART N</u></b>
CB510	INVERTER BOARD	CB510/W
CB511	TUBE SELECT BOARD	CB511/W
CB512	DRIVER BOARD	CB512/W
CB513	POWER RELAY BOARD	CB513/W
CB514	PROCESSOR BOARD	CB514/W
CB515	INVTERFACE BOARD	CB515/W
CB517	MOTHER BOARD	CB517/W
EXTENDER	EXTENDER BOARD ASSY	CB4X5EXT
HS2-1C1	AC CAP 25MFD @ 370	97F9006
HS2-1C1A (Q)	AC CAP 15MFD @ 440	97F9037
HS2-1C2	AC CAP 6MFD @ 660	26F6623FA
HS2-1C2A (Q)	AC CAP 20MFD @ 440	97F9039
HS2-1C3	AC CAP 3MFD @ 440	97F5437
HS2-1C4 (Q)	AE CAPACITOR	36DX2000-450VDC
HS2-1CR1	BRIDGE RECTIFIER	35MB120A (IR)
HS2-1F1	FUSE SLO-BLO	MDL 1/2
HS2-1F2	FUSE SLO-BLO	MDL 1/2
HS2-1F3	FUSE SLO-BLO	MDL 1-1/2
HS2-1F4	FUSE SLO-BLO	MDA 7
HS2-1F5	FUSE SLO-BLO	MDA 7
HS2-1F6	FUSE SLO-BLO	MDA 7
HS2-1FH1	1-1/4 FUSE HOLDER	HKP
HS2-1FH2	1-1/4 FUSE HOLDER	HKP
HS2-1FH3	1-1/4 FUSE HOLDER	HKP
HS2-1FH4	1-1/4 FUSE HOLDER	HKP
HS2-1FH5	1-1/4 FUSE HOLDER	HKP
HS2-1FH6	1-1/4 FUSE HOLDER	HKP
HS2-1K1	R/Q RELAY	HG4-DC-24V
HS2-1R1 (Q)	RESISTOR	RH50-.2 OHM 1%
HS2-1R2 (Q)	RESISTOR	RH50-.2 OHM 1%
HS2-1R3 (Q)	RESISTOR	RH50-.2 OHM 1%
HS2-1R4	RESISTOR	RH50-10 OHM 1%
HS2-1SS1	SOLID STATE RELAY	SSR600240R55
HS2-1T1	AUTOTRANSFORMER	5944
HS2-1T2	TRANSFORMER	5251
HS2-CB1 (Q)	CIRCUIT BREAKER	ULP-11-1-66-203
HS2-CB1 (R)	CIRCUIT BREAKER	ULP-11-1-66-103
HS2-LF1	LINE FILTER	20VB1

# Shimadzu Medical Systems



## National Technical Support

20101 S. Vermont Ave. Torrance, Ca. 90502

Tel. (800) 228-1429 Fax. (310) 217-0729

## SERVICE BULLETIN

Model: HMS Starter and UD150B-30/L-30

Date: 10/19/98

Number: XR-980014

Title: HMS starter interface to the UD150B-30/L-30

Checked by: \_\_\_\_\_

Approved by: \_\_\_\_\_

Issued by: Gordon Bowler

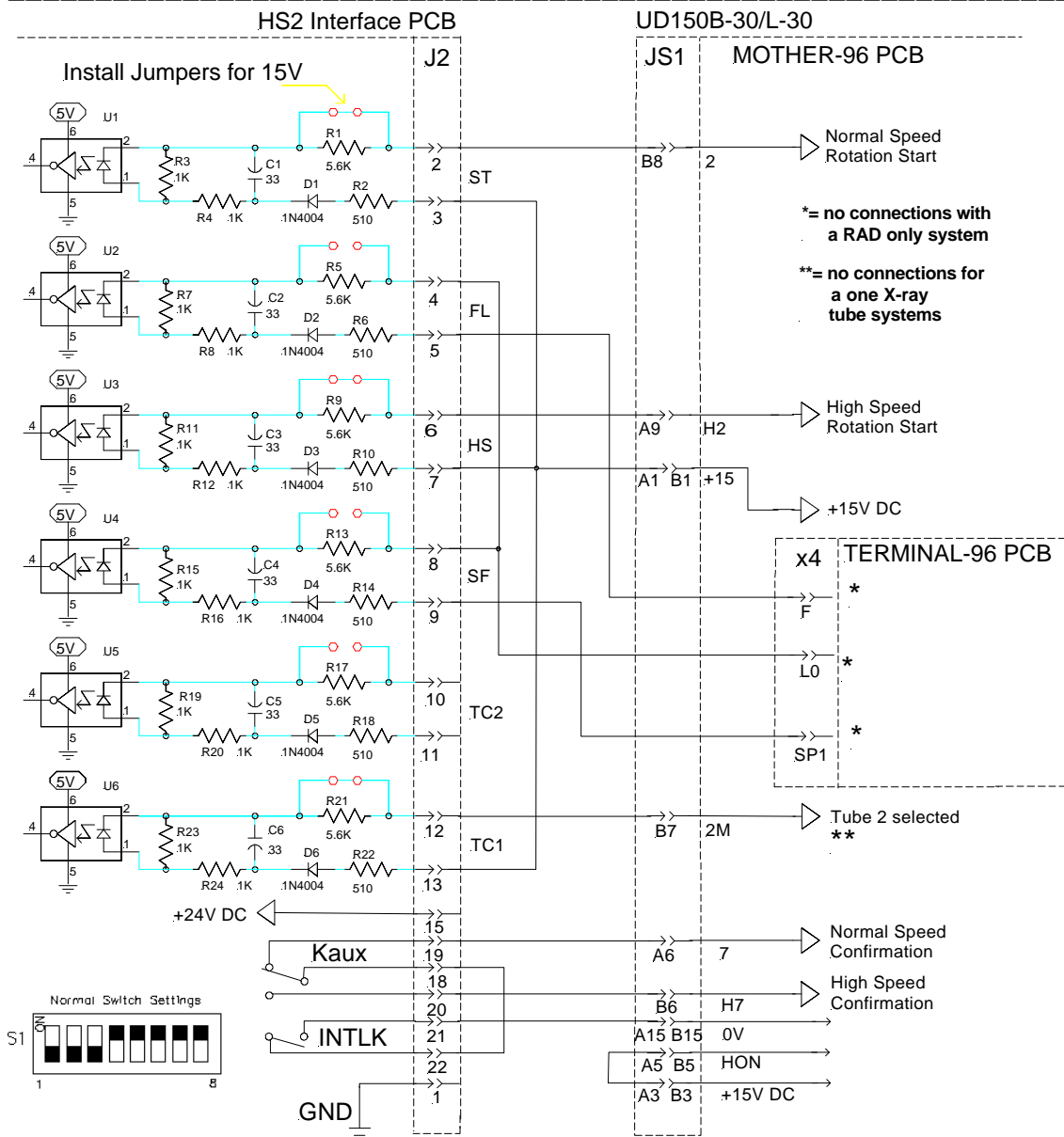

CAUTION: DO NOT MIX +15V DC AND L100 POWER SUPPLIES  
 VERIFY ALL JUMPERS ON THE HMS INTERFACE PCB  
 Reference the connection diagrams in the UD150B-30/L-30 schematics  
 for MOTHER-96 (3/17) and TERMINAL-96 (5/6) PCB's.

# Shimadzu Medical Systems



## National Technical Support

20101 S. Vermont Ave. Torrance, Ca. 90502  
Tel. (800) 228-1429 Fax. (310) 217-0729

## SERVICE BULLETIN

Model: HMS Starter and UD150L-F/R/II

Date: 10/19/98

Number: XR-980015

Title: HMS starter interface to the UD150L-F/R/II

Checked by: \_\_\_\_\_ Approved by: \_\_\_\_\_

Issued by: Gordon Bowler

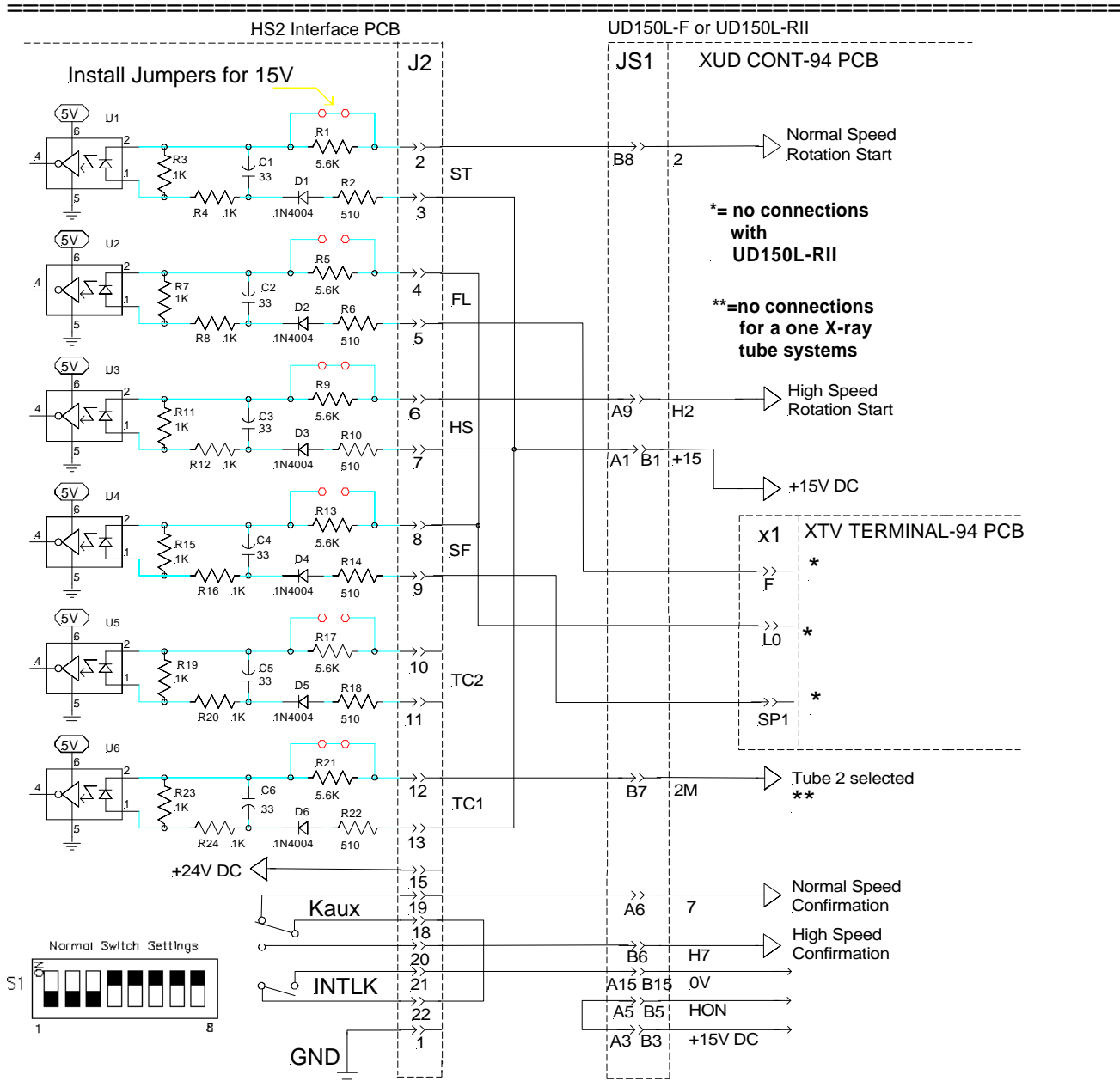

CAUTION: DO NOT MIX +15V DC AND L100 POWER SUPPLIES  
VERIFY ALL JUMPERS ON THE HMS INTERFACE PCB  
Reference the connection diagrams in the UD150L-F/R/II schematics  
for XUD CONT-94 (7/13) and XTV TERMINAL-94 PCB's.